



10 Gallon Water Boiler



READ AND SAVE THESE INSTRUCTIONS

NOTICE TO INSTALLER: Please leave this booklet with the machine.

Key Features/Specifications/System Requirements..... FS52

Important Safeguards..... IS2

Installation Instructions (General).....II20

Installation Instructions (Water Supply, Electrical)II25

Operating InstructionsOI39

Cleaning Instructions..... CI16

Rough-In Drawing..... RD58

Illustrated Parts/Recommended Parts..... IP97

Electrical Schematic.....ES95

Troubleshooting Guide (General).....TG22

Troubleshooting Guide (Heating Element Circuit).....TG30

Troubleshooting Guide (Thermostat Adjustment).....TG37

Product Warranty.....PW1

Contact Information

Wilbur Curtis Co., Inc.

6913 Acco Street | Montebello, CA 90640 US
Phone: 323-837-2300 | Toll Free: 800-421-6150
Email: csrcassistance@wilburcurtis.com | Web: www.wilburcurtis.com

For the latest specifications and information go to www.wilburcurtis.com
Toll Free: 800-995-0417 | Monday - Friday 5:30 A.M. - 4:00 P.M. PT
Email: techsupport@wilburcurtis.com

Due to continued product improvement, the products illustrated/photographed in this guide may vary slightly from the actual product.

Key Features

- Automatic Refill System – For hot water anytime.
- Industry's most mineral tolerant design.

Specifications (Selected Models)

Electrical Supply Requirements

MODEL #	DESCRIPTION	PHASE	VOLTS	AMPS	HEATING CONFIG	WIRE	WATTS	HERTZ	GAL/HR
WB-10-12	10.0 Gallon - domestic	1 PH	120/220 V	17.3/31.8 A	2 X 3500 W	2/3W + G	2080/7000 W	50/60 Hz	5.9/20.0
WB-10-60	10.0 Gallon - export	1 PH	230 V	33.3 A	2 X 3500 W	2W + G	7650 W	50/60 Hz	20.0

Dimensions

Water Supply Requirements

MODEL #	HEIGHT	WIDTH	DEPTH	SHIP WEIGHT	SHIP CUBE	WATER CONNECTOR	WATER PRESSURE	MIN. FLOW RATE
WB-10-12	31.00"	16.88"	18.00"	35.0 lbs	6.47 cu ft	1/4" flare	20 - 90 psi	1.0 gpm
WB-10-60	31.00"	16.88"	18.00"	35.0 lbs	6.47 cu ft	1/4" flare	20 - 90 psi	1.0 gpm

Symbols



This is the safety alert symbol. It is used to alert you to potential physical injury hazards. Obey all safety messages that follow this symbol to avoid possible injury or death.



DANGER - Indicates a hazardous situation which, if not avoided, will result in death or serious injury.



WARNING - Indicates a hazardous situation which, if not avoided, could result in death or serious injury.



CAUTION - Indicates a hazardous situation which, if not avoided, could result in minor or moderate injury.



NOTICE - Indicates a situation which, if not avoided, could result in property damage.



IMPORTANT - Provides information and tips for proper operation.



SANITATION REQUIREMENTS



WARNING - This product can expose you to chemicals including Acrylamide and Bisphenol A (BPA), which are known to the State of California to cause cancer and birth defects or other reproductive harm. For more information visit www.P65Warnings.ca.gov.

Important Safeguards/Conventions



WARNING:

- Make sure that this appliance is installed and grounded according to the INSTALLATION INSTRUCTIONS by qualified personnel before attempting to use it. Failure to follow the INSTALLATION INSTRUCTIONS could result in personal injury or void the warranty.
- This appliance is designed for commercial use. Any service other than cleaning and preventive maintenance should be performed by an authorized Wilbur Curtis service technician.
- To reduce the risk of fire or electric shock, DO NOT open the service panels. There are no user serviceable parts inside.
- Keep hands, arms and other items away from hot surfaces of the unit during operation.
- Clean the appliance and any dispensers completely before using them for the first time according to the CLEANING INSTRUCTIONS. Clean them regularly as instructed in the CLEANING INSTRUCTIONS.
- Use this appliance only for its intended use, brewing/dispensing hot and/or cold beverages/water.
- This appliance is not intended for use by persons (including children) with reduced physical, sensory or mental capabilities or lack of experience and knowledge, unless they have been given supervision or instruction concerning use of the appliance by a person responsible for their safety. Children should be supervised to ensure that they do not play with the appliance.
- Avoid spillage onto the power (mains) connector.

CE Requirements

- This appliance must be installed in locations where it can be overseen by trained personnel.
- For proper operation, this appliance must be installed where the temperature is between 5°C to 35°C.
- Appliance shall not be tilted more than 10° for safe operation.
- An electrician must provide electrical service as specified in conformance with all local and national codes. For safe use, an all-pole disconnection must be incorporated into the fixed wiring in accordance with the wiring rules outlined in clause 7.12.2 of IEC 60335 for meeting the minimum electrical safety of this standard.
- This appliance must not be cleaned by water jet.
- This appliance can be used by persons aged from 18 years and above if they have been given supervision or instruction concerning use of the appliance in a safe way and if they understand the hazards involved.
- Keep the appliance and its cord out of reach of children aged less than 18 years.
- Appliances can be used by persons 18 years and above with reduced physical, sensory or mental capabilities or lack of experience and knowledge if they have been given supervision or instruction concerning use of the appliance in a safe way and understand the hazards involved.
- Children under the age of 18 years should be supervised to ensure they do not play with the appliance.
- If the power cord is ever damaged, it must be replaced by the manufacturer or authorized service personnel with a special cord available from the manufacturer or its authorized service personnel in order to avoid a hazard.
- Machine must not be immersed for cleaning.
- Cleaning and user maintenance shall not be made by children unless they are older than 18 years and supervised.
- This appliance is intended to be used in household and similar applications such as:
 - staff kitchen areas in shops, offices and other working environments;
 - by clients in hotels, motels and other residential type environments;
 - bed and breakfast type environments.
- This appliance not intended to be used in applications such as:
 - farm houses
- Access to the service areas permitted by Authorized Service personnel only.
- The A-Weighted sound pressure level is below 70 dBA.



WARNING: Installation is to be performed only by a qualified installer.



WARNING: Improper electrical connection may result in an electric shock hazard. This brewer must be properly grounded.



NOTICE: DO NOT connect this appliance to a hot water supply. The water inlet valve is not rated for hot water. Do not exceed the maximum water pressure stated in the **SPECIFICATIONS** section.



IMPORTANT: Observe all governing codes and ordinances.

Installation Instructions

Installation Requirements

- A secure surface capable of supporting the weight of the appliance.
- For units without an attached cord set: Appropriately sized, UL listed, grounding type power cable to meet the electrical specifications for the appliance. If you have questions about the correct cable size and length, consult a qualified installer. If the unit will be hard wired to a junction box, the power cable must be long enough so that it can be moved for cleaning underneath.
- A grounded electrical connection to an electrical circuit that meets the electrical specifications of the appliance (see **SPECIFICATIONS**). The circuit must be protected by the appropriate sized circuit breaker. If you are not certain that the existing circuit meets the requirements for your unit, consult a licensed electrician.
- A water filtration system is required to maintain trouble-free operation. Wilbur Curtis Co., Inc. recommends a Wilbur Curtis approved water filter. See the Curtis Equipment Catalog for a full line of Wilbur Curtis approved water filters.
- Potable water supply line connection from the water filter capable of supplying the minimum flow rate required by the specifications. The water supply line must be able to connect to the flare fitting on the back of the brewer. See the **SPECIFICATIONS** section for the correct size. The water line should also be capable of being controlled by a shut off valve. Do not connect the water line to a saddle or needle valve.



NSF International requires the following water connection:

- 1 A quick disconnect or additional coiled tubing (at least two times the depth of the brewer) is required so that it can be moved for cleaning underneath.
- 2 This equipment is to be installed with adequate back-flow protection to comply with applicable federal, state and local codes.
- 3 Water pipe connections and fixtures directly connected to a potable water supply shall be sized, installed and maintained in accordance with federal, state and local codes.

The International Plumbing Code of the International Code Council and the Food and Drug Administration (FDA) Food Code manual, direct that this equipment must be installed with adequate back-flow prevention in compliance with federal, state and local codes. For units installed outside of the U.S.A., make sure that the installation is in compliance with the applicable plumbing/sanitation code for your area.

Installation

NOTICE: Before proceeding, make sure that the counter is capable of supporting at least 120 lbs. to allow for the water boiler at full capacity.

Connect the Power Cord

- 1 Lay the unit on its side, on a padded surface, with the bottom of the unit exposed.
- 2 Remove the bottom cover from the unit.
- 3 On units that will be operated at 120 Vac, disconnect the red wire from the "L2" terminal on the power block and reconnect it to the "N" terminal.
- 4 Feed the end of the power cable, through the strain relief, into the unit and connect it to the power block according to the *ELECTRICAL SCHEMATIC*.
- 5 Tighten the strain relief. Do not connect the other end of the power cable at this time.
- 6 Replace the bottom cover and tip the unit up into the vertical position.

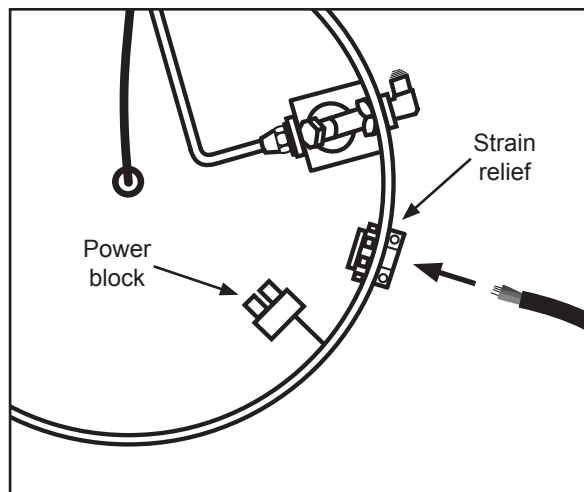

Bottom View - Cover Removed

Leveling

- 7 Position the water boiler on the countertop. Make sure it is level left to right and front to back.

Connect the Water Supply

- 8 Flush the water supply line prior to installation to purge air and debris from the water filter and tubing.
- 9 Connect the water supply line to the flare fitting on the back of the unit.
- 10 Turn on the water supply valve and check for leaks.

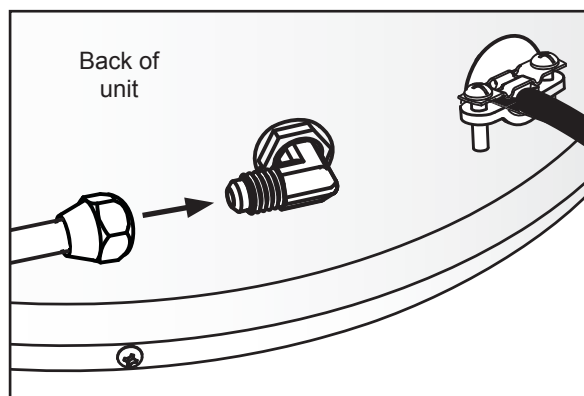

Connecting the Power Cable (220 - 240 Volt Operation)



WARNING: Turn off power to the junction box at the circuit breaker panel before connecting the power cable. Lock out and tag the circuit breaker.

- 11 Connect the power cable wires to the terminals in the junction box. See the *ELECTRICAL SCHEMATIC* for the power supply requirements.

Powering up the Unit

- 12 Make sure the knob on the thermostat is in the OFF position.

Units Operating on 220 - 240 Volts:

- 13 Turn on power to the circuit breaker supplying power to the junction box.

Units Operating on 120 Volts:



WARNING: Connect the power cord only to the appropriate type and size electrical outlet. If the electrical outlet is not compatible with the power cord, have it upgraded by a licensed electrician. Do not modify the power plug. Do not use an extension cord. Do not use a power cord/plug that is damaged.

- 14 Make sure that the circuit breaker supplying power to the electrical outlet is on.
- 15 Connect the power cord to the appropriate type of electrical outlet.

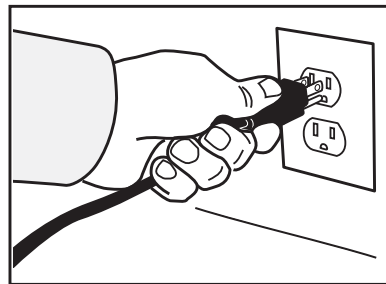

All Units:

- 16 When power is connected, the water inlet valve will open, filling the unit. While the tank is filling, you may hear the sounds of air being purged from the filter, tubing and water tank.
- 17 Once the water tank is full (you will hear the water stop flowing), turn on the boiler at the thermostat, by twisting the knob clockwise.
- 18 Depending on the incoming water temperature and the electrical specifications, the water tank typically requires 50 to 60 minutes to reach the factory set operating temperature. The light on the thermostat will come on when the water is hot.
- 19 Dispense 6 ounces of hot water through the faucet to help purge any remaining air.



WARNING: AVOID SCALDING. This unit dispenses hot water.

- 1 The unit must be connected to power and the thermostat needs to be set to the desired temperature.

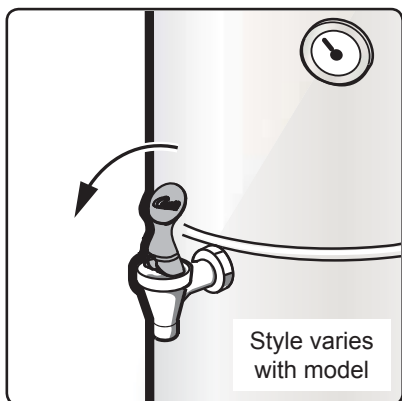

- 2 Hold a cup under the faucet and pull forward on the handle to dispense.

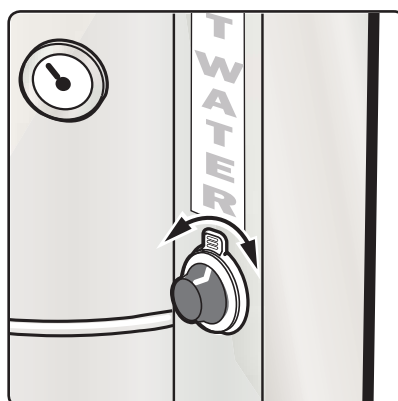

- 3 Turn the thermostat knob to the desired setting. The indicator light comes on when the heating element is heating the water.

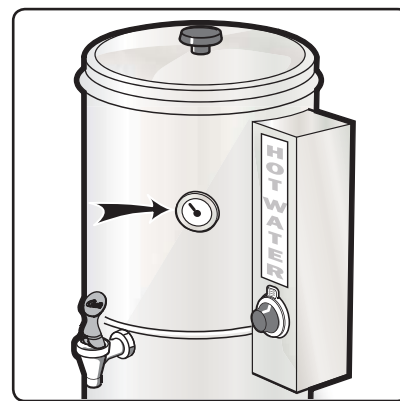

- 4 The thermometer indicates the current water temperature.



WARNING: HOT SURFACES - To avoid injury, allow the unit to cool 30 minutes before cleaning.



NOTICE - Do not use cleaning liquids, compounds or powders containing chlorine (bleach) or corrosives. These products promote corrosion and will damage the finishes. **USE OF THESE PRODUCTS WILL VOID THE WARRANTY.**

Cleaning The Water Boiler and Dispensing Head - Daily or As Needed



WARNING: DO NOT immerse the water boiler in water or any other liquid.

The water boiler should be OFF. Turn the unit off by turning the rear toggle switch to the OFF position. Allow it to cool.

- 1 Wipe exterior surfaces with a soft, damp cloth soaked with a mild detergent solution to remove spills and debris.
- 2 Rinse with a soft cloth soaked with clean water to remove any residual detergent. Then dry.
- 3 If applicable, remove the drip tray screen and rinse it off. Wipe out the interior of the drip tray with a soft, damp cloth. Replace the screen.

Flushing the Pre-heat Coil (Corinth Models) - Twice a Year

It is recommended that the pre-heat coil be flushed twice a year by a qualified technician according to the instructions in the *Troubleshooting* section.

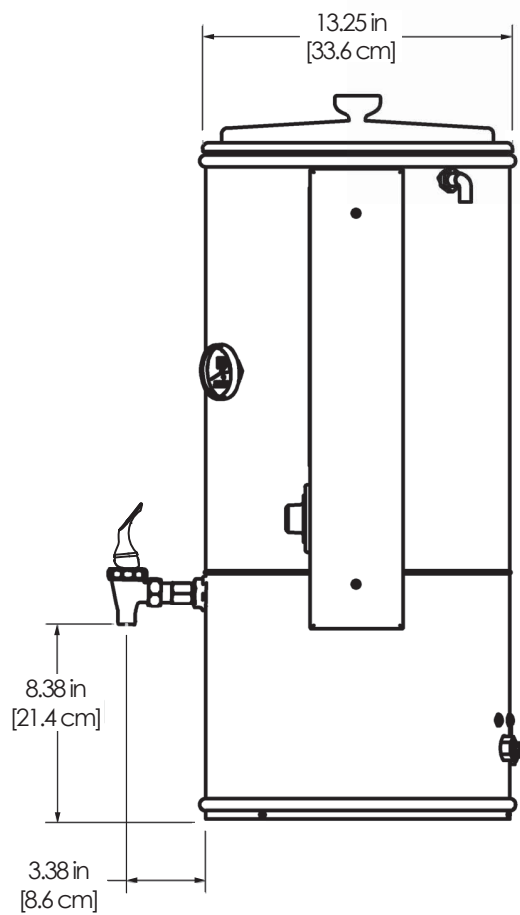
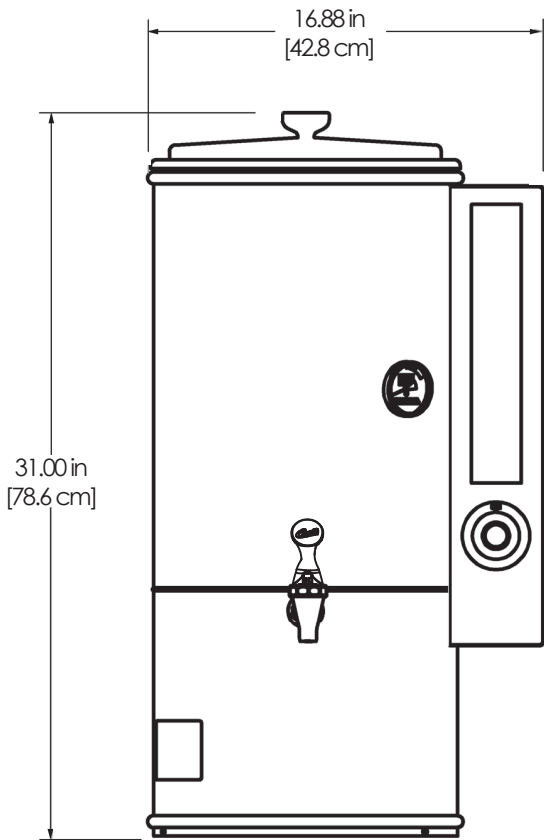
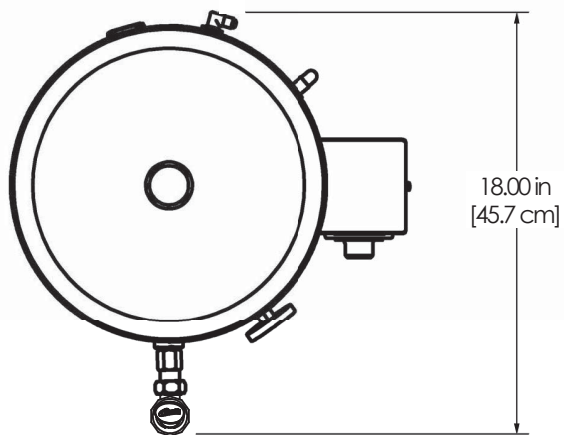

WB-10-12/60 - Main Chassis - Exploded View

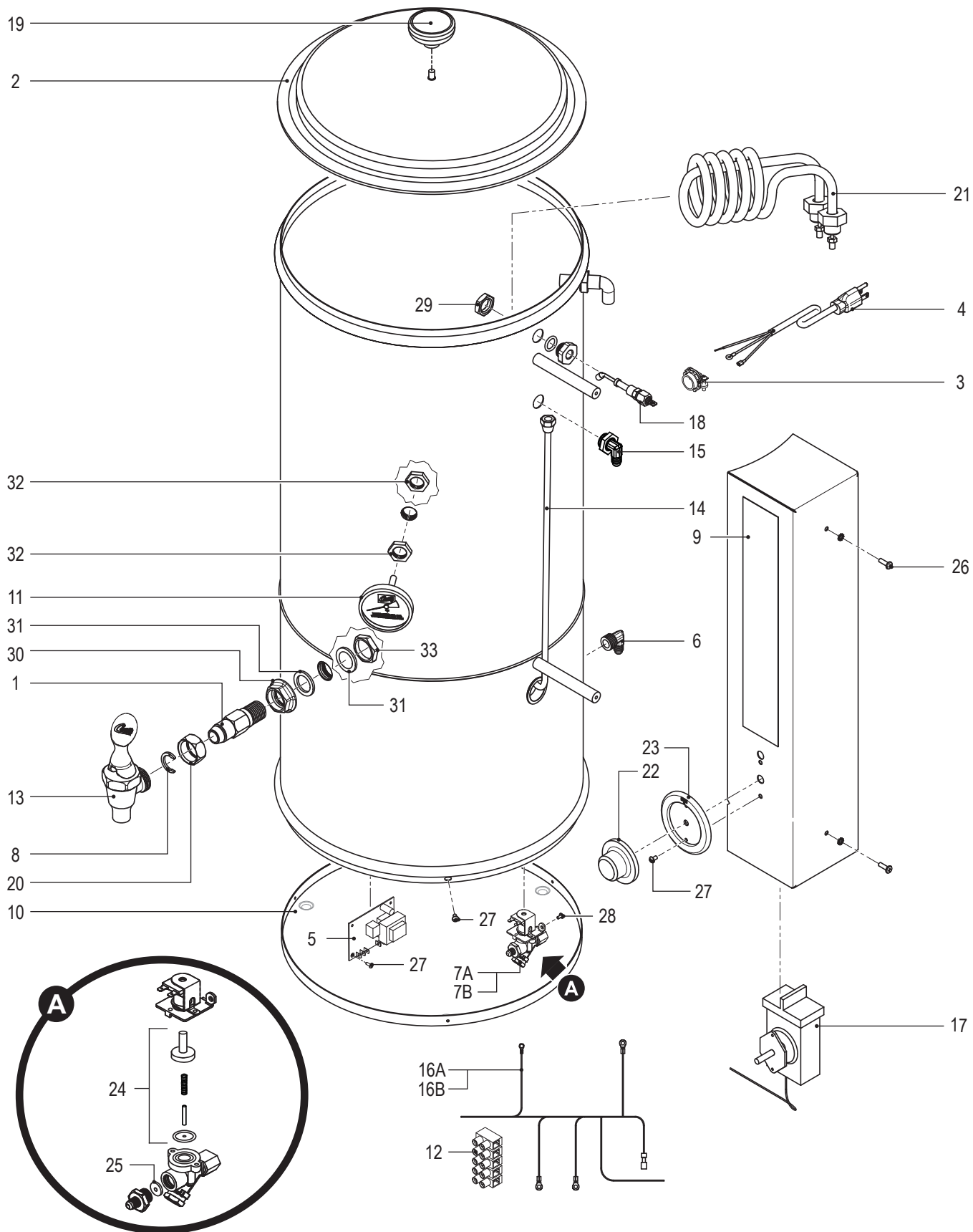

WB-10-12/60 - Main Chassis - Parts List

ITEM #	PART #	DESCRIPTION
1	WC-1902	SHANK, FAUCET PLAIN
2	WC-5602	LID, W/KNOB TC-10
3	WC-1412	CORD GRIP, 3/4" FOR METAL CORD TO .81"OD
4	WC-1200 ¹	CORD, 14/3 SJTO 6' BLK W/PLUG
5	WC-10030	CONTROL MODULE, 120/220V LIQUID LEVEL/BREW TIMER
6	WC-2401-P	ELBOW 3/8 NPT X 1/4 FLARE PLTD
7A	WC-801 ¹	VALVE, INLET BRASS .50 GPM 120V 10W RU/WB
7B	WC-858 ²	VALVE, INLET BRASS .50 GPM 220V 10W
8	WC-1906	"C" RING .917 X .760 X .090 TT-3 TC'S
9	WC-3914	LABEL, HOT WATER (PANEL) WB-10
10	WC-5611	COVER, BOTTOM WB-10
11	WC-511	THERMOMETER, DIAL RU'S
12	WC-314	POWER BLOCK, 5 STATION
13	WC-1800HW	FAUCET ASSY, RED HANDLE 1-1/32 -14 UNS CURTIS
14	WC-5386	TUBE, ASSY WATER INLET WB-10-12
15	WC-2999	FITTING, WATER INLET PLATED
16A	WC-13228 ¹	HARNESS, ASSY WB-10-12 (NOT SHOWN)
16B	WC-13299 ²	HARNESS, ASSY WB-10-60 (NOT SHOWN)
17	WC-501	THERMOSTAT, CAPILLARY DPST 277V 30A W/ BEZEL RU/WB

¹WB-10-12, ²WB-10-60

Recommended Parts to Stock

ITEM #	PART #	DESCRIPTION
5	WC-10030	CONTROL MODULE, 120/220V LIQUID LEVEL/ BREW TIMER
7A	WC-801	VALVE, INLET BRASS .50 GPM 120V 10W RU/WB

ITEM #	PART #	DESCRIPTION
18	WC-5502-01	KIT, PROBE, ASSY WATER LEVEL W/HEX FITTING, O-RING & NUT
19	WC-3205	KNOB, LID 1/4-20 FEMALE THRD USE ON WC-5601/5602/5603
20	WC-1903	NUT, UNION SHANK WB-10/WB-10-60/WB-30-12
21	WC-922-04	KIT, ELEMENT HEATING 3.5KW 220V W/JAM NUTS & SILICONE WASHERS
22	WC-3217	KNOB, ELECTRIC THERMOSTAT RU
23	WC-3220	BEZEL, THERMOSTAT ELECTRIC URN'S
24	WC-3700	KIT, INLET VALV REPAIR USE ON WC-801/801R/885/890/858
25	WC-813	FLOW WASHER, .5GPM .5" S45
26	WC-4503	SCREW, 8-32x1/2 PHILLIPS HEAD
27	WC-4439	SCREW, 6-32x1/4 PHIL PAN HD SS
28	WC-4616	SCREW, 1/4-20 x 1/2 PHILLIPS PAN HEAD STAINLESS STEEL
29	WC-4212-P	NUT, 5/8-18 JAM UNF SS
30	WC-1939	NUT, FLANGED TLS-2, GEM3, RU'S
31	WC-1813	WASHER, 1-1/8" OD ETHYLENE PROPYLENE RUBBER
32	WC-4211	NUT, 3/8 JAM NPSM NICKEL PLATED W/O WASHER FACE
33	WC-4214P	NUT, 1/2" JAM 304SST.

ITEM #	PART #	DESCRIPTION
17	WC-501	THERMOSTAT, CAPILLARY DPST 277V 30A W/ BEZEL RU/WB

WB-10-12

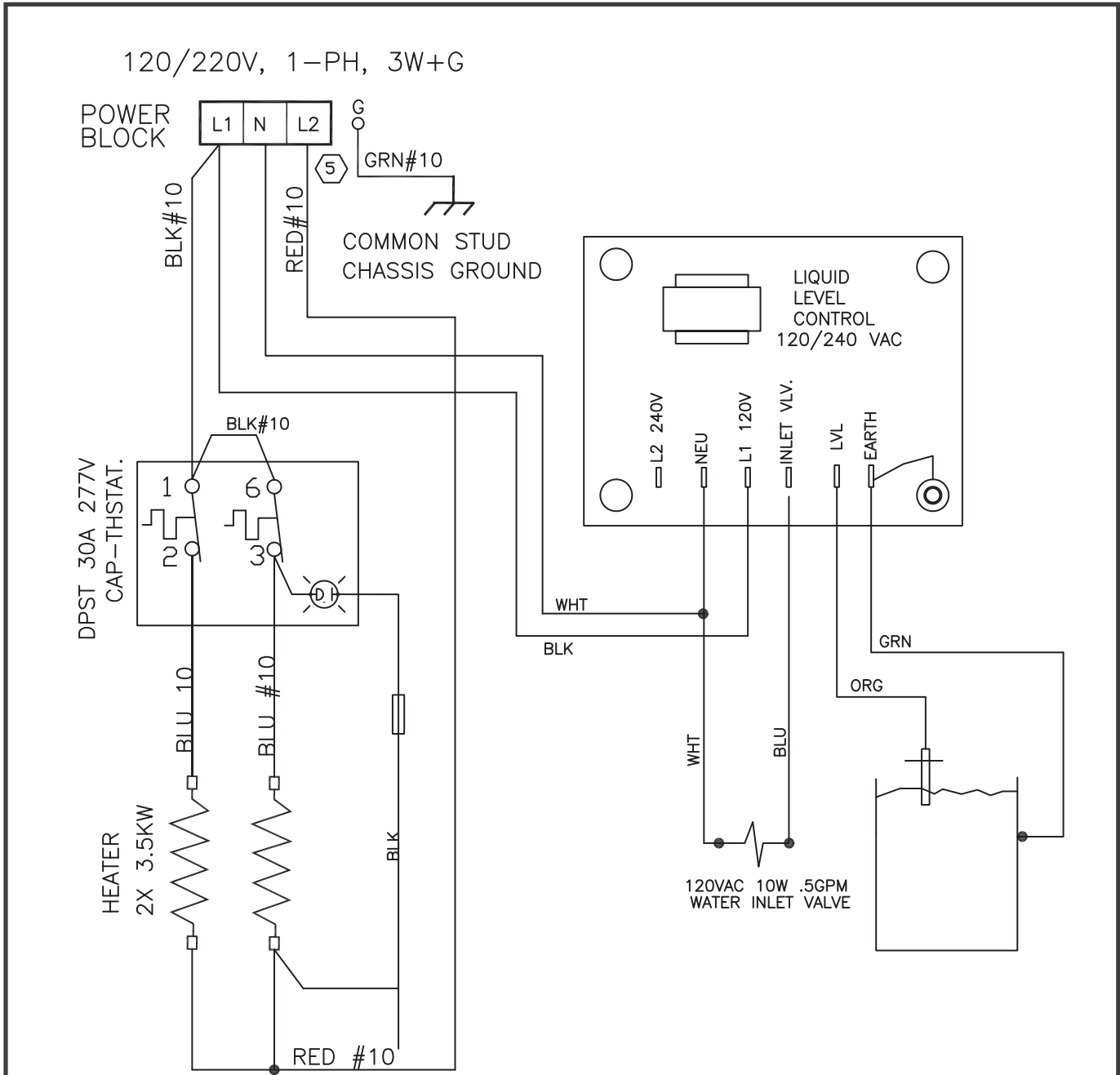

VOLT	WATTS	AMPS	WIRE	HZ	PHASE
120V	2080W	17.3A	2W + G	50/60Hz	1
120/220V	7000W	31.8A	3W + G		

5) FOR 120V (2W+G) CONNECTION, REMOVE RED#10 FROM L2 AND CONNECT TO "N" AT THE TERMINAL BLOCK

4 FACTORY DEFAULT IS 220VAC/3W+G

3 USE THIS DIAGRAM FOR OTHER MODELS WITH ADDED PREFIX AND/OR WITH SECOND DASH NUMBER ON THEIR PART NUMBERS PROVIDED THEY HAVE THE SAME ELECTRICAL SPECS. EXAMPLE: SCWB-10-XX

2 DO NOT CHANGE NOR SUBSTITUTE WIRE COLORS.

1 ALL WIRES SHALL BE 18AWG UL APPROVED APPLIANCE.

NOTES: UNLESS OTHERWISE SPECIFIED

VOLTAGE:	SEE TABLE
WATTAGE:	SEE TABLE
AMPERAGE:	SEE TABLE
HERTZ:	SEE TABLE
WIRES:	SEE TABLE
PHASE:	1 PH

TITLE:	WIRING DIAGRAM WATER BOILER 10GAL	
PART NUMBER:	WD-WB10-12	REVISION:
		B

WB-10-60

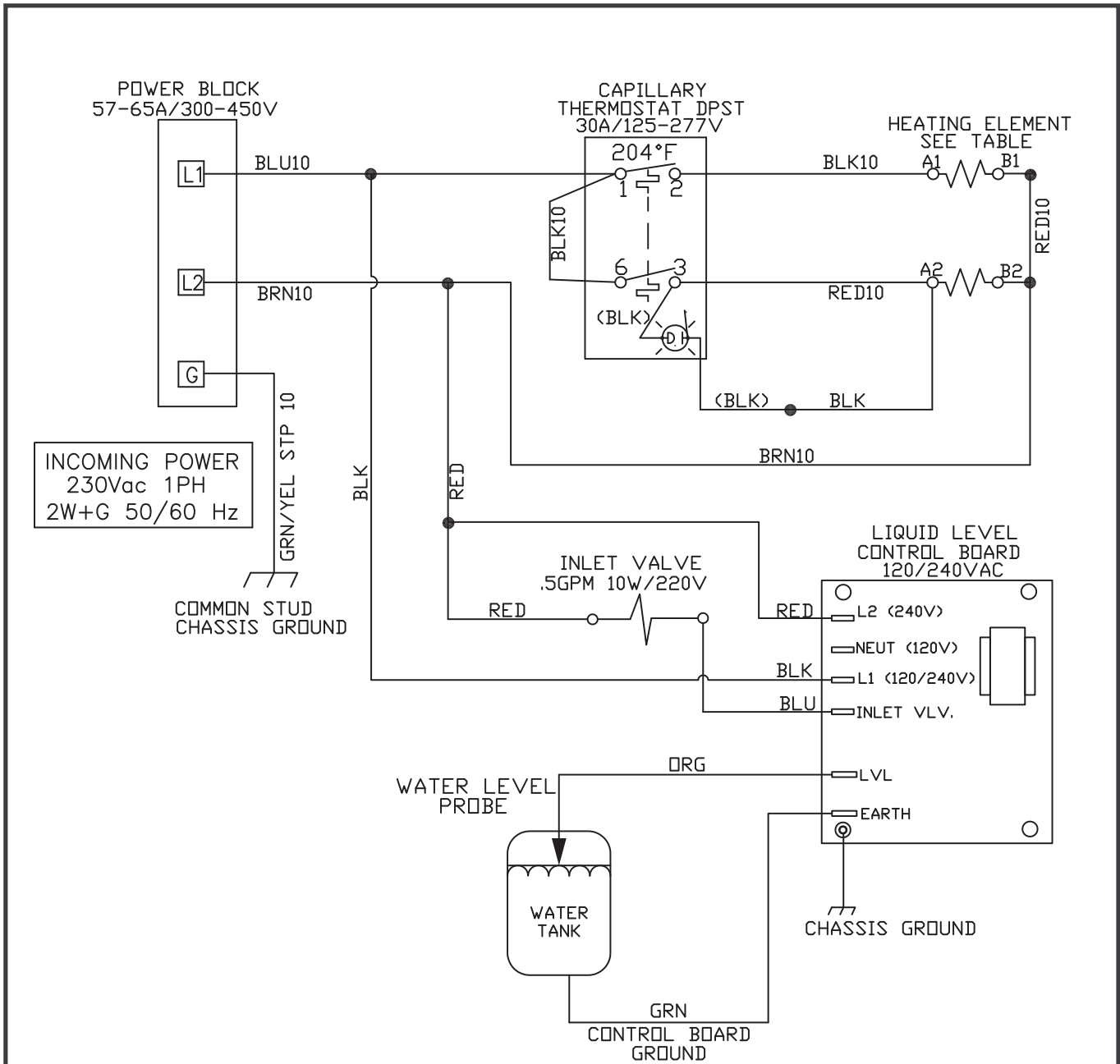

ELECTRICAL RATING TABLE								
Model	Voltage V	Amps A	Watts W	Hertz Hz	# of Conductor Wires	Phase	# of Tank Elements	Tank Element Rating W/V
WB-10-60	230	33.3	7650	50/60	2	1	2	3500W/220V
WB-10-6098				60				

2. USE THIS DIAGRAM FOR ALL OTHER MODELS WITH ADDED PREFIX LETTERS AND/OR SUFFIX NUMBERS ON THEIR PART NUMBERS HAVING THE SAME ELECTRICAL RATINGS.
 1. ALL WIRES SHALL BE MIN 18AWG PVC PER UL1015.
 NOTES: UNLESS OTHERWISE SPECIFIED.

VOLTAGE:	SEE TABLE
WATTAGE:	SEE TABLE
AMPERAGE:	SEE TABLE
HERTZ:	SEE TABLE
WIRES:	2W+G
PHASE:	1 PH

TITLE: WIRING DIAGRAM WATER BOILER 10GAL.	
PART NUMBER: WD-WB10-60	REVISION: G

**WARNING:**

Electric Shock Hazard - the following procedures are to be performed only by a qualified service technician. Disconnect power when replacing components. Neither Wilbur Curtis Co., Inc. nor the seller can be held responsible for the interpretation of this information, or any liability in connection with its use.

Scald and Burn Hazard - keep body parts clear of hot surfaces during troubleshooting.



NOTICE: After replacing or emptying the water tank, be sure to run the First Time Power Up Instructions in the Installation Instructions section. Failure to do so may result in damage to the unit.

Troubleshooting Guidelines

- A water boiler that is not level may not function properly. Make sure the unit is properly leveled before proceeding.
- This troubleshooting guide identifies some, but not all, of the possible causes for common problems that can occur.
- Use this troubleshooting guide along with the appropriate *ELECTRICAL SCHEMATIC*.

Valve Test Procedure

Use a digital multi-meter to measure the resistance of valve coils.

Measure the resistance across the valve coil terminals with the wiring harness disconnected. Reverse the meter leads on the terminals and measure the resistance in the opposite direction. A resistance of less than 100 ohms, in either direction, indicates a shorted coil. The valve must be replaced.

If a shorted coil is not detected, test for an open coil:

- 1 Reconnect the valve terminals to the wiring harness.
- 2 Power up the unit with the appropriate cover removed to allow access to the valve.
- 3 Monitor the voltage at the inlet valve coil terminals. If voltage is present on the terminals, you should hear the valve click open/closed at the moment power is applied or removed from the terminals. The inlet valve should open any time the water tank is not full. If the valve does not open, replace the valve. If voltage is not detected, first check the wiring, then trace the fault back to the source.

No Power

- 1 Make sure the circuit breaker to the circuit supplying power to the unit is not tripped and is turned on.
- 2 On units with a power plug, make sure it is connected to the power receptacle.
- 3 Make sure that the main power toggle switch (if applicable) is turned ON.
- 4 Verify that all wires from the power cord are properly connected inside the unit. Check to make sure the wires are not burned/overheated. Loose connections create heat. Check chassis ground.

Water Tank Does Not Fill

IMPORTANT: No water or low water in the tank can cause the tank to overheat, resulting in the thermostat reset switch opening. If after correcting a tank fill problem there is no power to the control panel, wait for the water tank to cool and push the reset switch button to reset.

- 1 Check to make sure the water supply is turned on. Check for a plugged water supply line, water filter or inlet valve.
- 2 If there are no plugs in the water supply line, check for power across the inlet valve terminals. If power is being supplied, but there is no water flow, replace the inlet valve.
- 3 If power is not being supplied to the inlet valve, check the wires between the liquid level control board and the inlet valve. Check for corroded connections.

- 4 If the wiring between the control board and the inlet valve is OK, but there is no power to the inlet valve, remove the orange wire from the water tank probe. If the water tank starts to fill, replace the probe. If the water tank does not start to fill, replace the control board.

Water Tank Overfills

- 1 Turn the main power toggle switch OFF (or unplug the power cord). If water continues to flow when the power is turned off, replace the inlet valve.
- 2 If water stops flowing to the water tank when power is off and resumes when power is on, remove the orange wire from the water probe on the tank. While power is on, short the end of the orange wire to the metal surface on the outside of the tank. If the water tank stops filling when the orange wire is shorted to the tank, check for a corroded connection at the water probe.
- 3 If water does not stop flowing when the orange wire is shorted to the tank, check the tank ground connection and the continuity of the orange wire connecting to the liquid level control board. Also check the ground connection to the liquid level control board. If all connections are OK, replace the control board.

Water Does Not Heat At All

- If the water heats, but is not hot enough, see *Water Not Hot Enough*.

The following steps are performed with the control box toggle switch in the ON position.

- 1 Check for power across the terminals of the heating element(s). If power is being supplied, remove the wires and check for an open heating element (nominal resistance is 13 Ohms).
- 2 If there is no power to the element, trace the circuit back (using the *ELECTRICAL SCHEMATIC*) to the power source(s) to find out where power is lost.

Water Heats More Slowly Than Usual

- 1 Check for the proper voltage across the terminals of the heating element.
- 2 If the proper voltage is being supplied, disconnect the heating element and check for high resistance (nominal resistance should be 13 Ohms). Replace a heating element if the resistance is too high.

Water Not Hot Enough

- 1 Check for the correct temperature setting on the thermostat knob.
- 2 Make sure that the water has had sufficient time to heat. Heating time for cold water can be up to 60 minutes.
- 3 If the temperature setting is OK, check the heating elements for high resistance (nominal resistance should be 13 Ohms). Also make sure all elements are getting power.
- 4 If the elements are OK, try adjusting the thermostat (see *Thermostat Adjustment*). Replace a thermostat that is stuck closed.

Water Too Hot (Boiling or Excessive Steaming)

IMPORTANT: When operating the unit at higher elevations, reduce the default operating temperature (200°F) by 2°F for each 1000 feet of elevation above 4000 feet. See *Thermostat Adjustment* on the following pages.

- 1 If operating the urn at higher elevations, check to make sure that the thermostat is not set too high. Re-adjust as instructed on the following page.
- 2 Check for a thermostat that is stuck closed. Replace as necessary.

Thermostat Adjustment

The thermostat is factory set to cut off at 200°F. If necessary, adjust it as follows:

- 1 Turn the main power switch OFF.
- 2 Rotate the thermostat knob to the right, to the BOIL position.
- 3 Pull off the knob.
- 4 In the thermostat stem, locate the tiny adjustment screw.
- 5 Using a small screwdriver, adjust the temperature up or down. Turning the screw ¼ turn to the left will increase the temperature about 20°F. Turning the screw ¼ turn to the right will decrease the temperature by 20°F.
- 6 Replace the knob.
- 7 To determine the temperature setting, turn the urn power switch ON, insert a thermometer probe into the water after about 60 minutes and re-adjust as necessary according to the steps above.

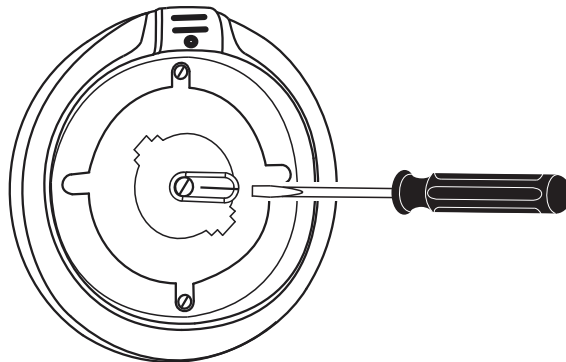

Wilbur Curtis Co., Inc. certifies that its products are free from defects in material and workmanship under normal use. The following limited warranties and conditions apply:

- 3 years, parts and labor, from original date of purchase on digital control boards
- 2 years, parts, from original date of purchase on all other electrical components, fittings and tubing
- 1 year, labor, from original date of purchase on all other electrical components, fittings and tubing

Additionally, Wilbur Curtis Co., Inc. warrants its grinding burrs for forty (40) months from the date of purchase or 40,000 pounds of coffee, whichever comes first. Stainless steel components are warranted for two (2) years from the date of purchase against leaking or pitting. Replacement parts are warranted for ninety (90) days from the date of purchase or for the remainder of the limited warranty period of the equipment in which the component is installed.

All in-warranty service calls must have prior authorization. For authorization, call the Technical Support Department at 800-995-0417. Additional conditions may apply. Go to www.wilburcurtis.com to view the full product warranty information.

CONDITIONS & EXCEPTIONS

The warranty covers original equipment at time of purchase only. Wilbur Curtis Co., Inc., assumes no responsibility for substitute replacement parts installed on Curtis equipment that have not been purchased from Wilbur Curtis Co., Inc. Wilbur Curtis Co., Inc. will not accept any responsibility if the following conditions are not met. The warranty does not cover:

- **Adjustments and cleaning:** *The resetting of safety thermostats and circuit breakers, programming and temperature adjustments are the responsibility of the equipment owner. The owner is responsible for proper cleaning and regular maintenance of this equipment.*
- **Replacement of items subject to normal use and wear:** *This shall include, but is not limited to, spray heads, faucets, light bulbs, shear disks, "O" rings, gaskets, silicone tubing, silicone elbows, canister assemblies, whipper chambers and plates, mixing bowls, agitation assemblies and whipper propellers.*

The warranty is void under the following circumstances:

- **Improper operation of equipment:** *The equipment must be used for its designed and intended purpose and function.*
- **Improper installation of equipment:** *This equipment must be installed by a professional technician and must comply with all local electrical, mechanical and plumbing codes.*
- **Improper voltage:** *Equipment must be installed at the voltage stated on the serial plate supplied with this equipment.*
- **Improper water supply:** *This includes, but is not limited to, excessive or low water pressure and inadequate or fluctuating water flow rate.*
- **Damaged in transit:** *Equipment damaged in transit is the responsibility of the freight company and a claim should be made with the carrier.*
- **Abuse or neglect (including failure to periodically clean or remove lime accumulations):** *The manufacturer is not responsible for variation in equipment operation due to excessive lime or local water conditions. The equipment must be maintained according to the manufacturer's recommendations.*

Repairs and/or Replacements are subject to Curtis' decision that the workmanship or parts were faulty and the defects showed up under normal use. All labor shall be performed during regular working hours. Overtime charges are the responsibility of the owner. Charges incurred by delays, waiting time, or operating restrictions that hinder the service technician's ability to perform service is the responsibility of the owner of the equipment. This includes institutional and correctional facilities. Wilbur Curtis Co., Inc. will allow up to 100 miles, round trip, per in-warranty service call.

Return Merchandise Authorization (RMA): All claims under this warranty must be submitted to the Wilbur Curtis Technical Support Department prior to performing any repair work or return of this equipment to the factory. **All returned equipment must be properly re-packaged in the original carton and received by Curtis within 45 days following the issuance of a RMA.** No units will be accepted if they are damaged in transit due to improper packaging. **NO UNITS OR PARTS WILL BE ACCEPTED WITHOUT A RETURN MERCHANDISE AUTHORIZATION (RMA). THE RMA NUMBER MUST BE MARKED ON THE CARTON OR SHIPPING LABEL. All warranty claims must be submitted within 60 days of service. Invoices will not be processed or accepted without a RMA number. Any defective parts must be returned in order for warranty invoices to be processed and approved.** All in-warranty service calls must be performed by an authorized service agent. Call the Wilbur Curtis Technical Support Department to find an agent near you.